

## Modular Servo Instructional Servo System

**MS150**

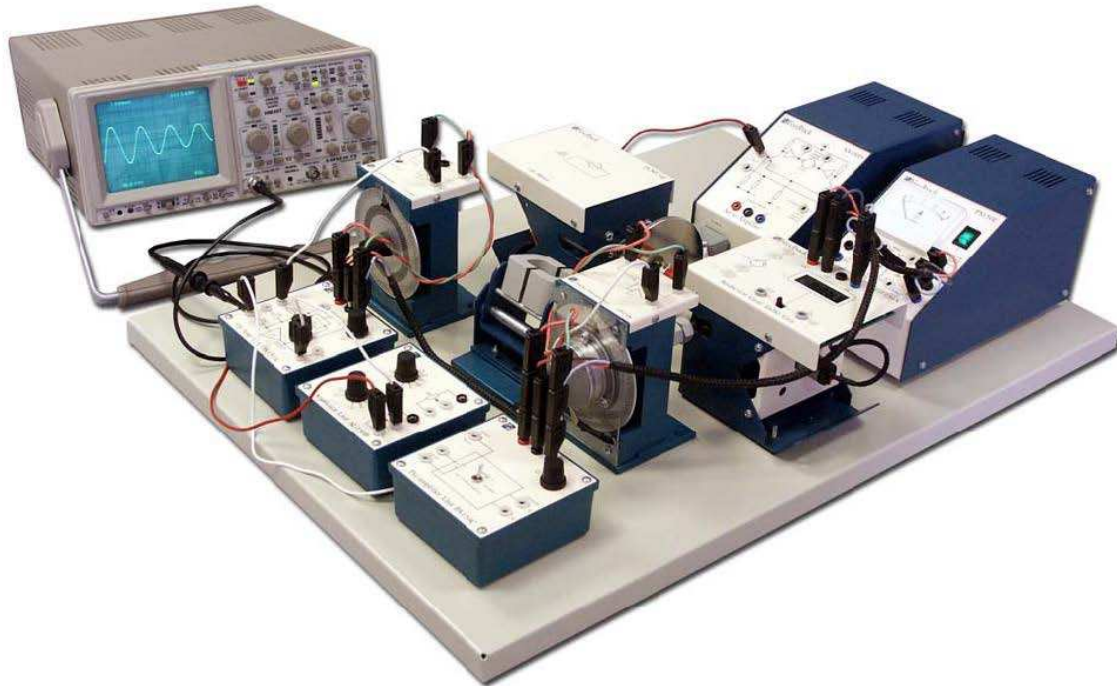

### Description

The MS150 Modular Servo System is a unique equipment designed to study the theory and practice of automatic control systems. It has been designed for teaching the theory of open and closed-loop, speed and positional control systems using modular units, both mechanical and electronic, that can be configured to demonstrate the various methods of control techniques. The MS150 comprises a baseplate and twenty units (see pages 7 and 8) which can be supplied as:

- a complete system MS150-3
- a d.c. system only MS150 (see page 2)
- an ac system only MS150A (see page 3)
- as a Digital system in a **MATLAB®** environment 33-008 or
- conversion sets to enable a change from one system
- to another (see page 4)

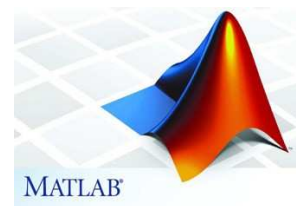

Each unit is fitted with a magnetic base which holds the unit to the plastic coated steel baseplate, irrespective of the angle at which the baseplate is positioned. Individual units may be so arranged to create operating block schematic systems and interconnections between the units are made by jumper leads terminated in 4mm stackable plugs.

The modular concept of the MS150 system permits the study of individual units and also, by combination, the investigation and performance testing of complete systems.

A series of instructional manuals (see page 6) is supplied to provide comprehensive coverage of servo system theory and assignments for a wide range of student abilities.

## Features

- Servo system comprises self-contained units with mimic diagrams of function blocks
- Magnetic base on each unit provides firm fixing to base-plate enabling practical visualisation of system block configurations
- Units may be investigated individually before building a system
- Easily extended to cover Digital systems
- No mechanical skills required to construct a working system
- "Hands-on" assembling of working systems
- Variable factors such as gain, damping, friction and inertia are immediately demonstrable by their effect on performance
- Demonstrations of stable and unstable modes by using switch-in time constant network
- Speed or position configurations may be built
- System protected against incorrect connections and accidental short-circuits

## DC Modular Servo System MS150

The d.c system MS150 is the basic set from which all other systems are derived. It is used for demonstrating and teaching automatic control techniques to students and technicians at all levels, e.g. **Technical and Craft schools Science and Physics courses Industrial training courses Universities, Teachers' Training Colleges, Military Training Schools, etc.**

The MS150 comprises modular units for individual study and construction of speed and position controls using d.c error signals. The MS150 system is extendible to cover:

- AC servo systems
- Hybrid servo systems
- Digitally controlled servo systems
- Relay (on/off) servo systems
- Sampled data systems
- Three-term control

Modules supplied are listed in the table on page 8. Book 3 (Advanced) assumes the ability to understand simple differential equations and the operator 'j'.

### Investigations include:

- Analysis of simple position control +/- speed response
- Position response
- Closed-loop frequency response
- Measurement of motor-time constant
- Measurement of velocity error constant
- Frequency & transient response
- Measurement of following error
- Stability considerations & the use of lead, lag & combined networks
- Tacho-generator feedback and its effects on system performance including acceleration feedback
- Linearisation of system

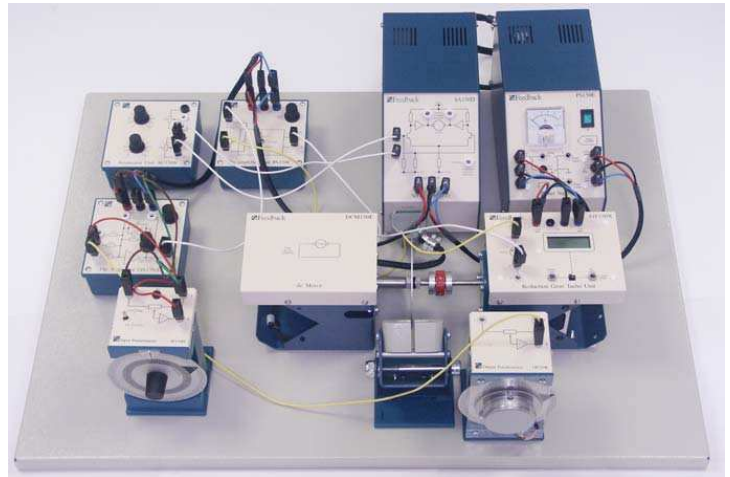

## Demonstrations and Assignments

The practical work is covered in the instruction manuals by Books 1 and 3. Book 1 (Basic) is largely qualitative and covers the initial introduction to control systems. Most work is non-mathematical and in the few cases where some knowledge is required, the formulae are of the elementary kind.

### Assignments include:

- Operational amplifiers
- Motor speed characteristics
- DC error channel
- Simple position control
- Closed-loop position control
- Simple speed control
- Dead-band and Step Response
- Velocity feedback

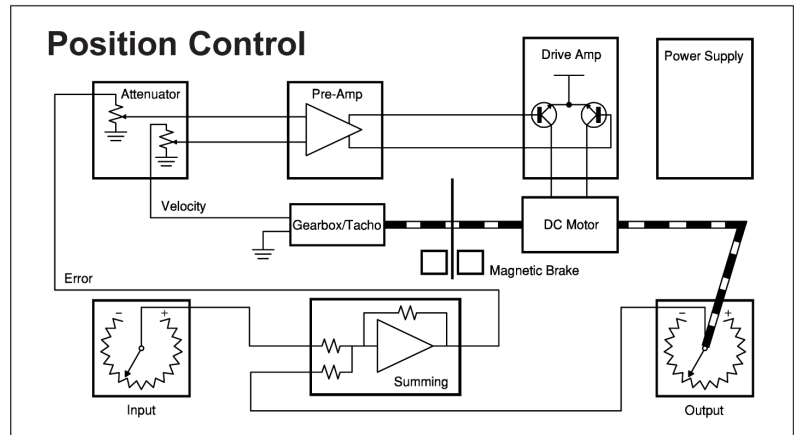
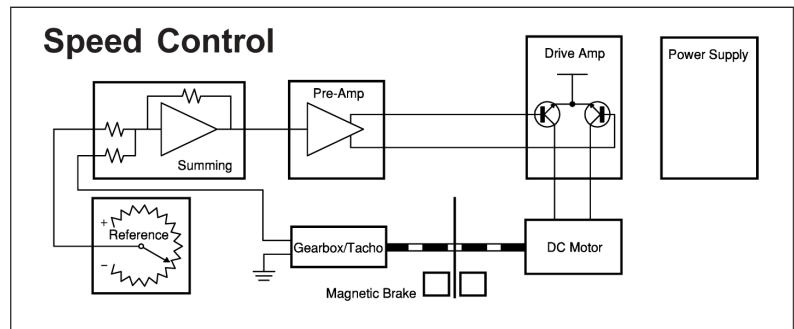

## Tender Specification for MS150

Modular servo trainer to permit construction and study of d.c. position and speed control systems of various types. To provide for external input, viscous and inertia loading and variation of principal parameters. To include three instruction manuals with basic theory and at least twenty practical activities on component characteristics, open and closed-loop behaviour & compensation techniques.



### Ancillary Equipment

To cover the full range of demonstrations and experimental work a function generator and a means to display the dynamic responses are essential. Feedback function generator FG601 is suitable. We recommend that the display oscilloscope has d.c coupled X and Y channels and has a simple storage facility.

## AC Modular Servo System MS150A

The ac system MS150A is used in more specialised and advanced control engineering courses where some detailed knowledge of ac carrier systems is required. It has the same basic form as the dc system and in fact uses some common components. As ac systems are fundamentally more complex than dc systems the theoretical work possible with

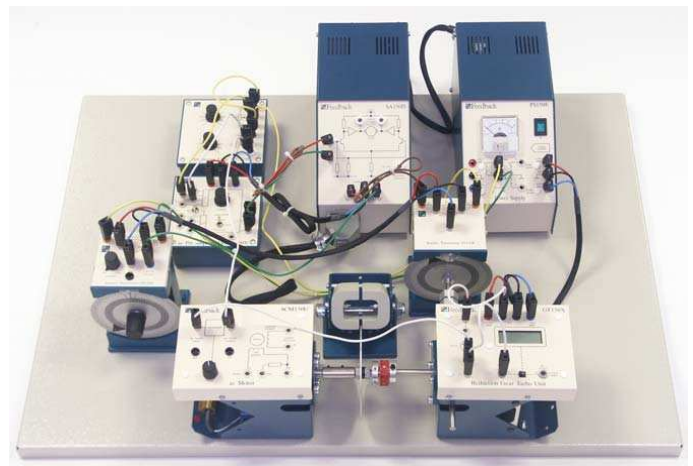

the MS150A is to a higher level than that for the MS150 dc system. The MS150A will have particular relevance to control engineering for Military and Aviation schools and for universities and colleges catering for the aerospace and advanced electronic industries.

### Demonstrations & Assignments

The Instruction Manuals contain progressive exercises with full theoretical explanations at each stage, commencing with a simple introduction in Book 1 and leading to more advanced work in Book 3.

- Motor characteristics
- AC tacho-generator
- Motor speed control
- AC pre-amplifiers
- Position control system
- The importance of correct phasing on performance
- Compensation using the adjustable notch filter
- Notch filter design exercises
- Frequency selective characteristics for the elimination of noise and harmonics
- Detailed analysis of carrier system
- Frequency transformation for compensator techniques
- Principles and measurement of compensation unit characteristics
- Measurement of system characteristics
- Instability
- Reduction in steady following error

### Tender Specification for MS150A

Modular servo trainer to permit construction and study of carrier type position and speed control systems of various kinds. To provide for external input, viscous and inertia loading and variation of principal parameters. To include three instruction manuals with at least eight practical activities and a theoretical discussion of dynamics, phasing and compensation by notch networks.

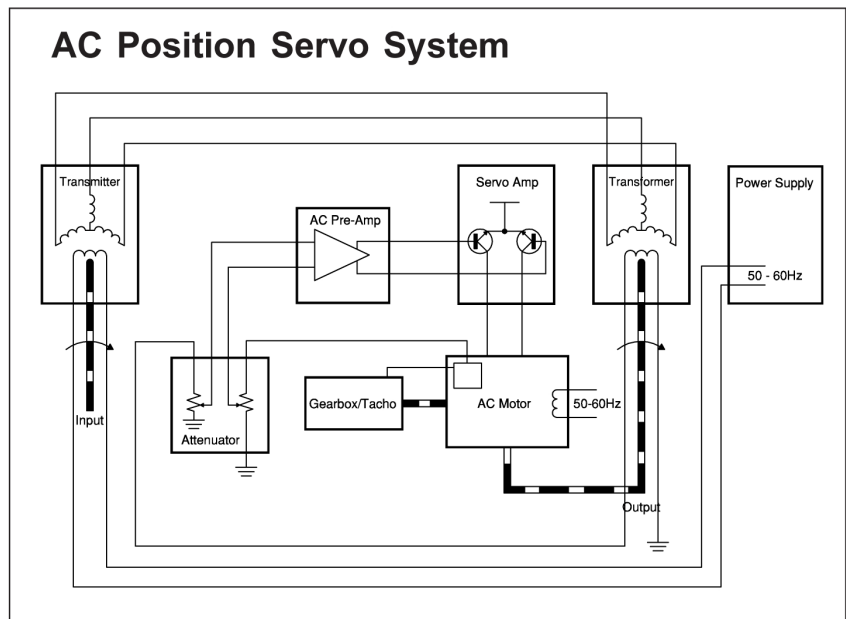

### Ancillary Equipment

To cover the full range of demonstrations and experimental work a function generator and a means to display the dynamic responses are essential. Feedback function generator FG601 is suitable. We recommend that the display oscilloscope has d.c coupled X and Y channels and has a simple storage facility.

### Modular Servo Conversion Sets

The dc system MS150 and ac system MS150A described on pages 2 and 3 are completely self-contained. They do however contain common components and thus it is possible to convert from one system to the other at minimal cost, providing in one package both ac and dc



systems. Conversion sets providing this facility are described below; these extend the work beyond individual dc and ac systems.

## Conversion from ac to dc systems



Customers in possession of the ac Modular Servo System MS150A who wish to extend their practical work to include dc systems will need to purchase the three units 150F, 150H and 150C.

### Tender Specification for 150CFH

Set of units to convert a carrier-type servo system to a dc system. To provide reference potentiometer, dc motor and dc pre-amplifier.

## AC/DC Hybrid System using Conversion Units 150RST

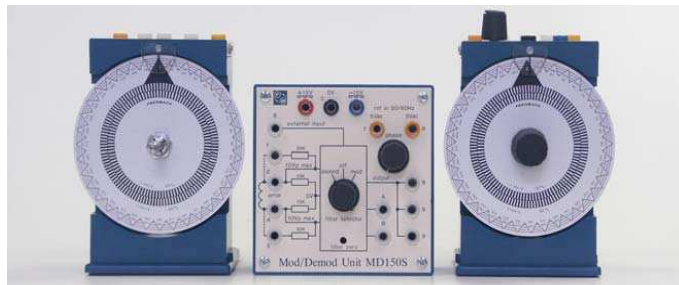

150RST consists of three units which enable the basic d.c MS150 to be converted to an a.c/d.c hybrid servo typical of many found in industrial processes.

### Range of Assignments

When used in conjunction with the MS150 the 150RST produces a continuous rotation position control system with ac error channel

using two synchros and a demodulator. These three units enable mainly qualitative assignments (Book 3) to be carried out; they cover exploratory work on synchros for data transmission and on associated equipment.

- The synchro link
- The demodulator
- Error channel sensitivity
- Closed-loop system
- Steady state following velocity feedback effect
- Improved steady state following with acceleration feedback
- Use of synchro link with 'defined time constant' system.

### Tender Specification for 150RST

Set of units to provide a dc servo system with an a.c. error channel based on synchro components. To provide synchro transmitter and receiver together with demodulator to convert a.c. error to d.c. To include teaching text with at least six practical activities and theoretical discussion of dynamic characteristics of synchro link servos.

## AC System using Conversion Units 150UVW

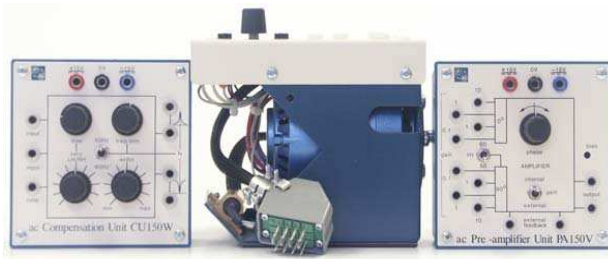

These three units when used in addition to the 150RST units and the dc MS150, fully convert the ac/dc hybrid system into a suppressed carrier ac system. The system uses a two-phase motor (150U), an a.c. pre-amplifier (150V) and a compensator unit (150W). The equipment is supplied with full theoretical explanations and suggested courses of practical work (Book 3).

### Range of Assignments

The assignments demonstrate the general characteristics of ac systems in a qualitative manner.

They include:

- Characteristics of a two-phase motor
- General behaviour of a closed-loop system
- Effects of gain and damping on stability
- The importance of correct phasing on torque and speed control
- Compensation using the adjustable notch filter
- Notch filter design exercises
- Frequency selective characteristics for elimination of noise and harmonics.

### Tender Specification for 150UVW

Set of units to convert a hybrid (ac error link) servo system to full ac operation. To provide an ac motor, ac pre-amplifier and an ac compensation facility. To include teaching text with at least eight practical activities together with a theoretical discussion of the dynamics of carrier servos, of phasing and of compensation by notch networks.

## Additional Units



### Simulated Relay Unit SR150G

The SR150G is an additional unit which greatly increases the scope of the dc MS150 by converting it into a relay (bang-bang or on-off) type control system with 2-step & 3-step control characteristics; it provides a wide range of electronically generated non-linear characteristics. The SR150G may also be used on its own to demonstrate the characteristics detailed below. The unit is provided with selector switches and controls that allow the generation of the following characteristics: Input drive voltage  $\pm 10V$  triangle waveforms at 5Hz nominal frequency.

### Demonstrations & Assignments

Practical work which can be carried out with the SR150G in conjunction with the MS150 DC Modular Servo System is given in Book 4:

- Relay characteristics-deadband-hysteresis
- Relay-operated control system
- Following characteristics of relay system
- Effect of backlash on system stability
- Relay-operated speed-control system
- Phase-plane analysis
- Motor characteristics - trajectories
- Trajectory for a sequence of switchings
- Phase-plane analysis of relay-operated systems
- Rotation of switching lines by velocity feedback

## Hybrid System

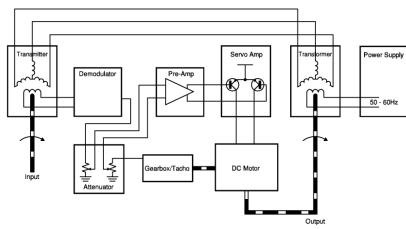

## AC System

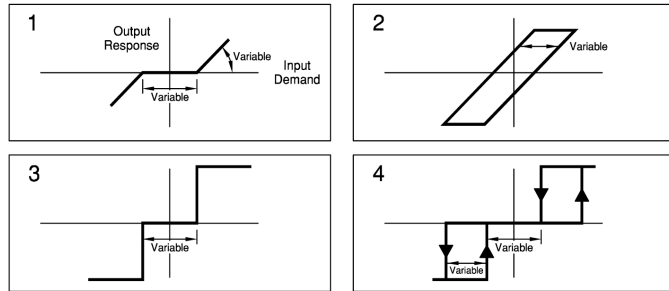
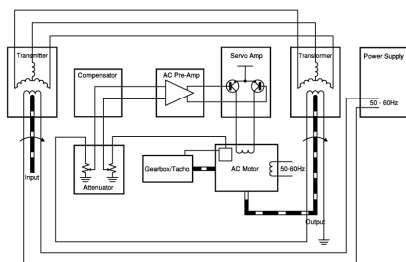

1. Deadband with variable slope.
2. Backlash with fixed unity slope.
3. Two-step and three-step without hysteresis (overlap).
4. Two-step and three-step with hysteresis (overlap).

### Tender Specification for SR150G

Add-on unit to adapt linear servo system to teach non-linear behaviour. To provide deadband, hysteresis, backlash, 2-step & 3-step characteristics, all with variable parameters. To include teaching text with at least six practical activities and introduction to phase-plane analysis.

### Proportional, Integral & Derivative unit PID150Y

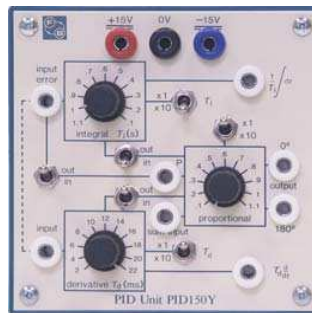

A further add-on unit is the PID150Y three-term control unit which can be used also with other d.c control systems. It provides a practical programme covering proportional, integral and derivative functions. Each path in the unit can be isolated from the others and is accessible via a monitoring socket. The three paths are combined in a summing amplifier with low-pass filtering characteristics, and an inverter is used to give 0° and 180° outputs. Variable time constants are provided in the integral and derivative functions to allow investigation of control loop characteristics. The instruction manual covers:

- Speed control of an MS150 servo
- Position control
- Following error
- Temperature control using the
- Feedback Process Trainer PT326
- and Appendices on PID control.

### Tender Specification for PID150Y

Add-on unit to provide full three-term control facilities for dc servos and other control system tutors. To provide proportional, integral & derivative error components all with variable parameters. To include teaching text with at least four practical activities and suggestions for further work and a theoretical introduction to three-term control techniques.

## Sample and Hold Unit SH150M



The addition of this unit to the MS150 dc Modular Servo System demonstrates the application of the principles of sampling theory to control systems. The unit consists of a zero order hold circuit and compatible pulse generator. The generator has an operating range of 0.1 to 100Hz in three decades. The unit has the standard MS150 module case with magnetic base and mimic diagram of the basic circuit. Assignments that form part of the accompanying manual (Book 5) include:

- Waveform sampling
- Sampled data servo control system
- Simulated sampled data control system
- Sampled data process control system with Appendices on Transfer functions of Hold Circuits, and the Sampling Theorem.

As the SH150M is fully compatible with most of the Feedback control systems, this means that there is a wide range of possible uses for the unit including demonstration of the application of Z-transforms.

### Tender Specification for SH150M

Add-on unit to adapt linear servo systems for zero-order hold sampled-data studies. To provide variable sampling rate and full trigger facilities. To include teaching text with at least five practical activities and introduction to sampled data theory.

## Differential Synchro DS150J



The DS150J is a differential synchro unit for use with the MS150A ac Modular Servo System. It is used in conjunction with the ST150T synchro transmitter and ST150R synchro transformer for demonstrating synchro operation. The DS150J is similar in appearance to the ST150R but it is fitted with a differential synchro in place of the synchro transformer and has a knob to set the differential angle. It can be inserted in the normal link between the ST150R and ST150T to illustrate the positioning of a transformer to an angle equal to the difference between the angles set on the transmitter and differential synchros. As there is an internal torque generated which tends to align the rotor and stator to zero differential, the dial is fitted with a braking pad. Six connections, three rotor and three stator, are brought out to the top panel.

### Tender Specification for DS150J

Add-on unit for hybrid and ac servo systems to illustrate the use of a differential synchro with other synchro components. To include operating instructions and suggestions for practical work.

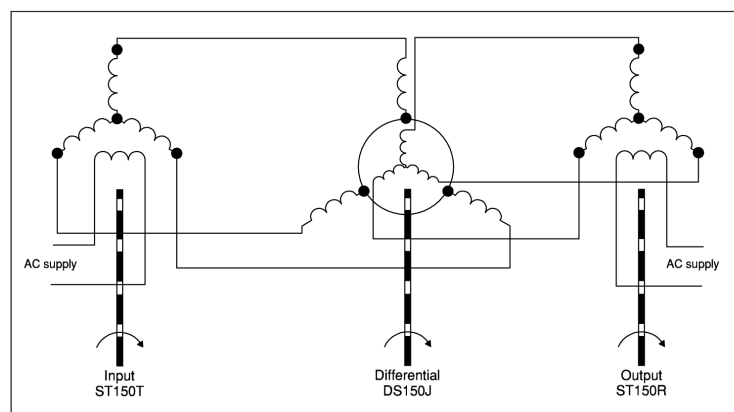



## Instruction Manuals



- Book 1 - dc, Synchro, and ac Basic Assignments
- Book 2 - Circuit Notes and Maintenance
- Book 3 - dc, Synchro and ac Advanced Experiments
- Book 4 - Simulated Relay System SR150G
- Book 5 - Sample and Hold unit SH150M
- Book 6 - Three-term control unit PID150Y

## Description of MS150 Units

### Operational Amplifier Unit OA150A

A general-purpose amplifier with facilities for multiple inputs and various feedback arrangements. Uses include summation to produce operating error for closed-loop systems, addition of extra time constants to demonstrate instability.

### Attenuator Unit AU150B

Twin calibrated potentiometers mounted in one case, available for gain and tacho-feedback control.

### Pre-Amplifier Unit PA150C

Has two input channels and a push-pull output for direct drive of the servo amplifier. Gain approx 25. Includes a switched defined time constant network.

### Servo Amplifier SA150D

Operates the motor to which it may be connected via a 12-way socket. A protective circuit limits the motor current under overload conditions.

### Power Supply PS150E

Supply input tappings are 100V, 110V, 120V, 200V, 220V 240V, 50/60Hz, 40VA. Output 24V dc, 2A unregulated, connects directly to the servo amplifier via a 12-way socket. Stabilised dc at  $\pm 15V$ , 150mA on 4mm sockets to operate smaller amplifier units and to provide reference voltages. 9V-0-9V rms at supply frequency on 4mm sockets to operate an ac error channel. 18V rms at supply frequency provide reference phase.

### dc Motor Unit DCM150F

This is a permanent magnet motor. The motor shaft is extended for direct mounting of the magnetic brake and inertia discs. Complete with the following accessories:

- 1 Inertia disk (thick).
- 1 Hexagonal spacer with hubs & collars.
- 1 Shaft 30mm long.

### Simulated Relay Unit SR150G

Converts the dc MS150 into a relay (banging or on-off) type control system with 2-step and 3-step control characteristics; it provides a wide range of electronically generated non-linear characteristics.

### Input & Output Potentiometers IP150H & OP150K

Semi-precision, servo-type potentiometers, mounted and fitted with calibrated position indicating dials. The output unit carries a rear extension shaft for coupling directly to the Reduction Gear Tacho Unit.

### Differential Synchro DS150J

A size eleven synchro of standard mechanical dimensions for use in conjunction with the ST150R and SR150T units.

### Loading Unit LU150L

Complete with Brake disc (thin). A fitting for the shaft mounts the aluminium disc which runs between the poles of a separately mounted permanent magnet. The pole/disc interference area may be adjusted against an arbitrary scale to provide a variable viscous load for the motor.

### Sample and Hold Unit SM150M

Consists of zero order hold circuit and compatible pulse generator with operating range of 0.1 to 100Hz in three decades.

### Synchro Transformer Unit ST150R

A size 11 synchro of standard mechanical dimensions and fitted with calibrated position-indicating dial including a stroboscopic disc; it is coupled directly to the motor low-speed output shaft by the Feedback coupler provided.

### Modulator/Demodulator MD150S

The demodulator section is a phase-sensitive rectifier & filter unit for use on 50 or 60Hz carriers. It has an adjustable phase-shift network covering 0° to nearly 180° to correct the reference input. In the demodulate condition the bandwidth is about 5Hz with the filter connected; with the filter 'off', experimental filters may be connected. The modulator section, with a bandwidth of about 60Hz, may be switched in to replace the demodulator, and is used in conjunction with the operational amplifier unit OA150A for injection of suppressed carrier test signals into the system.

### Synchro Transmitter Unit ST150T

A size 11 synchro of standard mechanical dimensions. Also contains an auxiliary drive motor, the armature of which is energised by an emitter follower, the speed being controlled by a potentiometer. The maximum speed is about 80 rev/min and the stroboscopic track on the calibrated dial permits accurate adjustment down to 1 rev/sec.

### ac Motor ACM150U

A two-phase ac induction motor which connects via a 12-way plug to the servo-amplifier. Reference and control phases are also connected to sockets on the front panel so that the motor waveforms can be monitored. A resistor in series with the reference phase limits the current during normal use. The modulator circuit transforms a dc tachogenerator signal (direction = dc voltage polarity and speed = dc voltage magnitude) into an ac tachogenerator signal (direction = signal phase with respect to motor ref. phase ie. in phase or antiphase and speed = magnitude). The phase adjust control allows fine adjustment when the complete system is set up. The motor shaft is extended for direct mounting of the magnetic brake and inertia discs. Complete with the following accessories:

- 1 Inertia disc (thick).
- 1 Hexagon spacer with hubs & collars.
- 1 Shaft 30mm long.
- 2 Spanners DE OJ, 18 x 19mm.

### ac Pre-Amplifier PA150V

This unit precedes the servo amplifier 150D (see diagram - page 4). It has facilities for summing the signals from two channels, one of which has a phase-adjusting control covering approximately 0° - 180°. An active filter network is available for use in the compensation experiments. This gives an analogue of a phase advance network when applied to the ac system.

### ac Compensator Unit CU150W

This unit provides transfers of the general form:

$$\frac{s^2 \pm 2\alpha\omega_c s + \omega_c^2}{s^2 \pm 2\alpha\omega_c s + \omega_c^2} ; \frac{\omega_c^2}{s^2 \pm 2\alpha\omega_c s + \omega_c^2}$$

representing a pair of complex poles in the denominator and a pair of complex zeros in the numerator, as indicated in the s-plane plot. The zeros can be moved from the left-half on to the imaginary axis (to give carrier rejection) and into the right-half plane to illustrate non-minimum phase characteristics. The poles can be set to the imaginary axis to give a sharp notch or resonance characteristic (bandwidth 1Hz). The centre frequency can be tuned to 50 or 60Hz carrier.

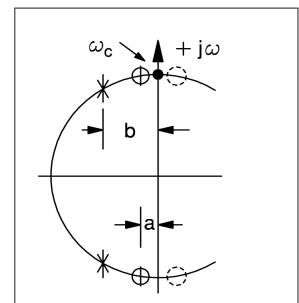

### Reduction Gear Tacho Unit GT150X

This contains a 30/1 ratio speed reduction gearbox and a dc tachogenerator driven from the high speed input shaft. A top panel display can be switched to indicate speed in r/min or to monitor an external dc voltage. Complete with the following accessories: 2 Hexagonal coupling, each complete with four 'o' rings.

### PID Unit PID150Y

This is a proportional plus integral plus derivative control unit for use with MS150 or other Feedback control systems using dc electrical signals.

### Ancillary Items MS150Z

Comprises:

- 1 Plastic coated steel baseplate.
- 8 Leads 4mm plug, 165mm, yellow.
- 4 Leads 4mm plug, 165mm, grey.
- 4 Leads 4mm plug, 270mm, red.
- 6 Leads 4mm plug, 270mm, orange.
- 2 Leads 4mm plug, 270mm, green.
- 6 Leads 4mm plug, 270mm, grey.
- 7 Leads 4mm plug, 570mm, yellow.
- 2 Leads 4mm plug, 570mm, green.
- 4 Leads 4mm plug, 570mm, grey.
- 6 Leads 4mm plug, 3 core.
- 2 Spanners DE OJ 1/4 x 3/16" BS.

### Power Supply requirements

PS150E Power supply - tappings at 100V, 110V, 120V, 200V, 220V, 240V 50/60Hz. All other modules require power of  $\pm 15V$ , 18V and 9-0-9V ac, 50/60Hz supplied from the PS150E.

### Connections

All connections via 4mm sockets. Power supply connections in three-lead flexible loom.

### Mounting

By magnetic bases onto plastic-coated steel base-plate, 720 x 520mm.

## Table 1 Ordering Information

### Modular Servo Systems

#### Units supplied with each equipment

MS150 dc system	A	B	C	D	E	F	H	K	L								X	Z			
MS150A ac system	A	B		D	E			K	L	R	S	T	U	V	W	X		Z			
MS150-2 ac/dc system	A	B	C	D	E	F	H	K	L	R	S	T	U	V	W	X		Z			
MS150-3 Complete Modular Servo	A	B	C	D	E	F	G	H	J	K	L	M	R	S	T	U	V	W	X	Y	Z

*For customers who would like to upgrade their existing MS150 system to be used with **MATLAB®** software (33-008), there is an Upgrade Pack 33-310-PCI available. It is not possible to upgrade very old versions of the MS150, so please contact Feedback Instruments or your local representative for advice on the best upgrade path if required.*

### Conversion sets

#### Units supplied with each equipment

150CFH from ac to complete ac/dc	C				F	H																
150RST from dc to ac/dc hybrid										R	S	T										
150UVW from hybrid to fully ac													U	V	W							
150RST/UVW from dc to fully ac										R	S	T	U	V	W							

### Additional units

#### Units supplied with each equipment

SR150G Simulated Relay							G															
DS150J Differential Synchro								J														
SH150M Sample and Hold										M												
PID150Y PID Control																					Y	
MS150Z Base unit and accessories																						Z

*Other combinations of sub-units can be supplied, quotations available on request.*

## Approximate Dimensions (mm) and Weight (kg)

Equipment	Unit pack				Equipment	Unit pack			
	Width	Depth	Height	Weight		Width	Depth	Height	Weight
MS150-3	720	520	203	24.4	150UVW	267	204	153	3.9
MS150-2	720	520	203	22.9	SR150G	107	107	67	0.33
MS150	720	520	203	17.5	DS150J	100	104	133	0.42
MS150A	720	520	203	20.0	SH150M	107	107	67	0.34
150RST	267	204	153	1.5	PID150Y	107	107	67	0.36

*Quantities packed for shipment are not necessarily multiples of figures given for each unit packs as packing varies with number of units ordered.*

## Tender Specifications

**MS150-3** - An instructional ac, dc or hybrid servo system in modular kit form, to teach the theory and operation of control system engineering. To include five instructional manuals.

**MS150-2** - An instructional ac or dc servo system in modular kit form, to teach the theory and operation of control system engineering. To include two instructional manuals.

**MS150** - An instructional dc system in modular kit form, to teach the theory and operation of control system engineering. To include two instruction manuals providing at least 10 assignments. Tender specifications for the Conversion sets and additional units are included within the leaflet.

## Ordering Information

Complete Modular Servo System MS150-3 or any combination of units from table 1 above.



### Feedback Instruments

5 & 6 Warren Court  
 Park Road, Crowborough  
 East Sussex  
 TN6 2QX  
 United Kingdom  
 Tel: +44 1892 653322  
 Sales: [sales@feedback-instruments.com](mailto:sales@feedback-instruments.com)  
 Website: [www.feedback-instruments.com](http://www.feedback-instruments.com)

For further information on Feedback equipment please contact ...

Feedback reserves the right to change these specifications without notice